

CUSTOMER DRAWING

©2007 CARCLO
ALL DIMENSIONS IN mm

ISS.	DATE	E.C.N.	DESCRIPTION
8	18-May-07		CUTOUT ADDED TO WALL CLIP WIDTH INCREASED

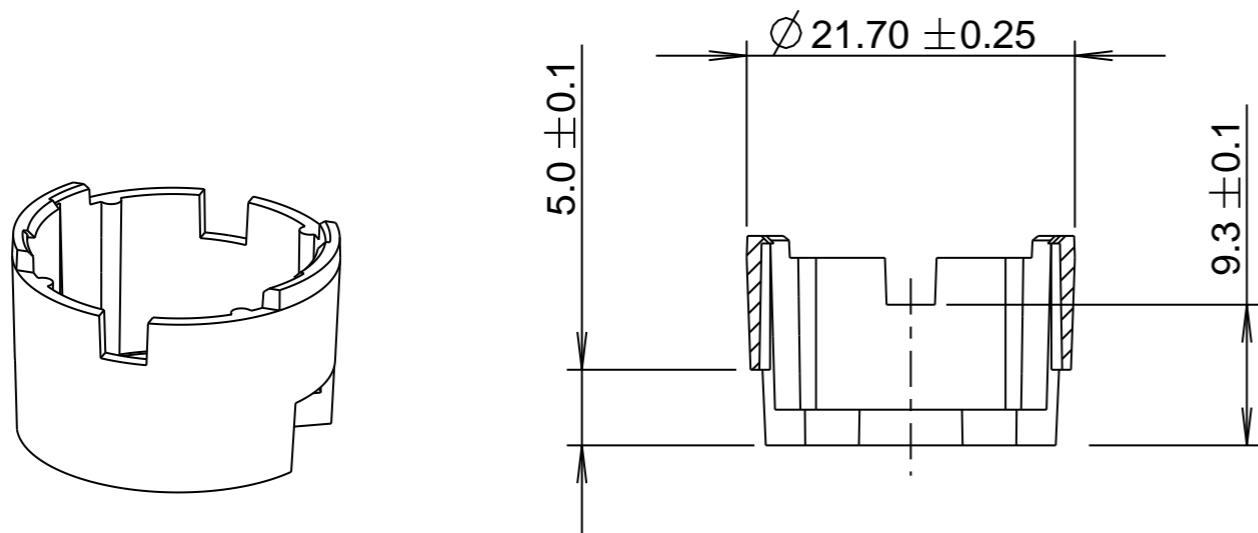
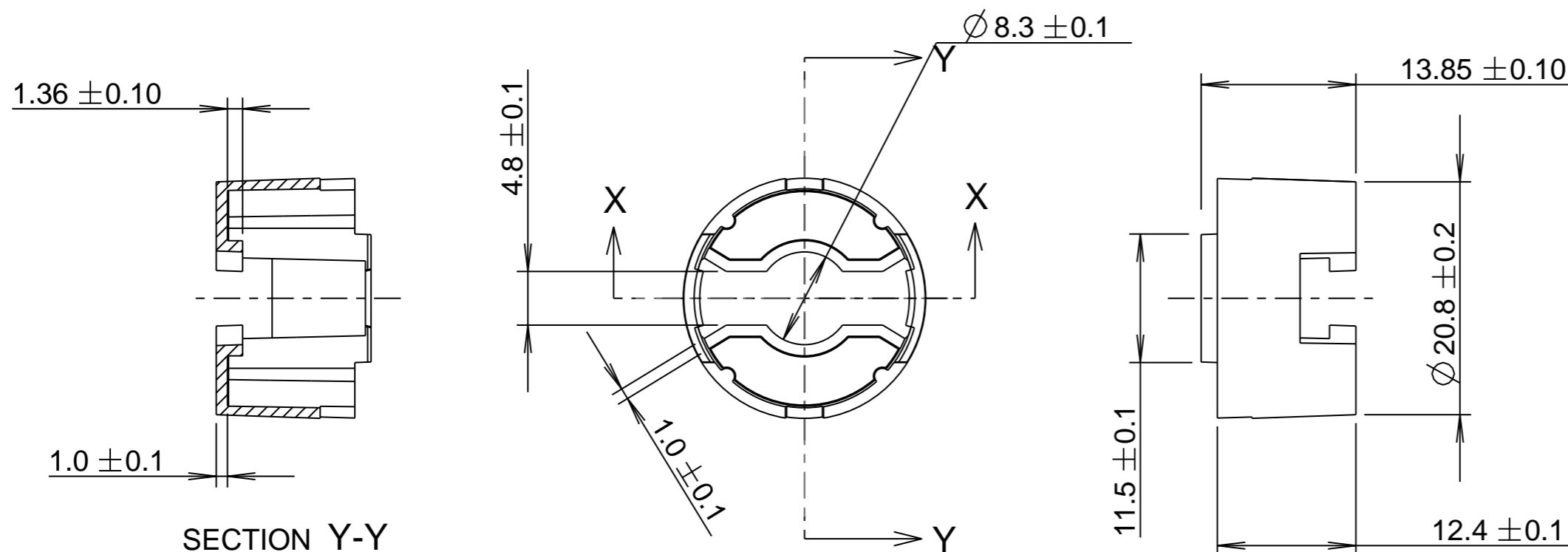

3D VIEW

SECTION X-X

 technical plastics
CARCLO TECHNICAL PLASTICS (SLOUGH)
 111 BUCKINGHAM AVE, SLOUGH
 SL1 4PF, ENGLAND
 TEL: +44 1753 575011 FAX: +44 1753 811359
 email: design@carclo-optics.com

GENERAL TOLERANCES (UNLESS STATED)

LINEAR		ANGULAR	
X	+/- 0.25	X	+/- 1°
X.X	+/- 0.1	X.X	+/- 0.5°
X.XX	+/- 0.05	X.XX	+/- 0.1°

CUSTOMER

TITLE
CIRCULAR LED OPTIC HOLDER

DRAWN **RJL** DATE 10-Jan-06

CHK'D DATE

APP'D DATE

SCALE 2:1 CARCLO PART No. SEE SHEET 1

SIZE A3 CARCLO DRG. No. 60323 SHEET 1 OF 1

PART No.	DESCRIPTION
10012	BLACK POLYCARBONATE
10024	CLEAR POLYCARBONATE
10035	WHITE POLYCARBONATE

- NOTES:-
1. MATERIAL: SEE TABLE
2. SEE SHEET 1 FOR INSPECTION DIMENSIONS